

# Hypertherm® HySpeed® HT2000®

## Consumables

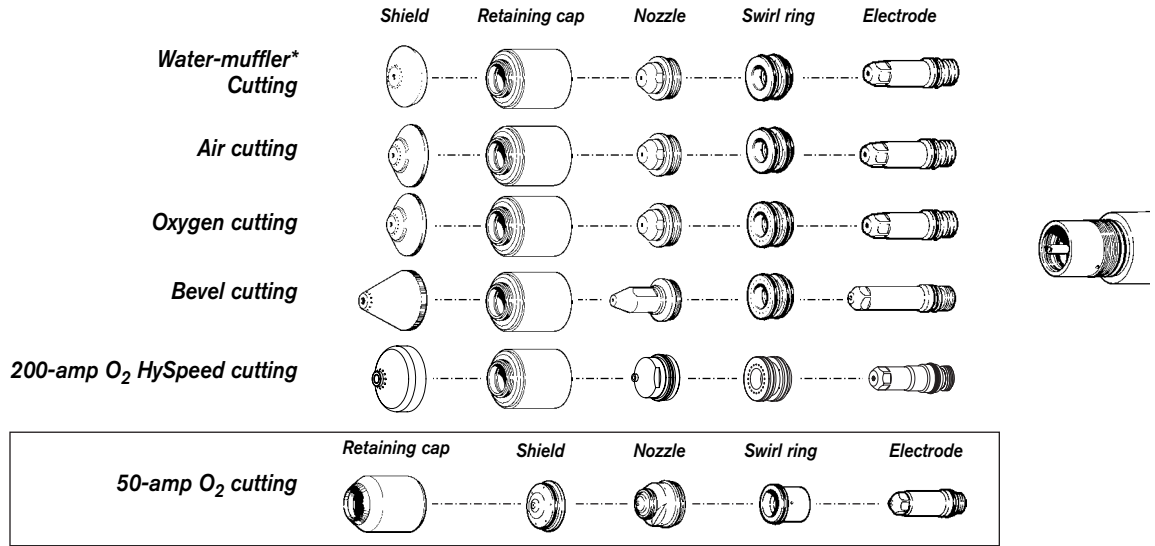

APPLICATION	PLASMA GAS	CONSUMABLE DESCRIPTION	PART NUMBER						
			200 AMP HySpeed	200 AMP BEVEL	200 AMPS	100 AMPS	50 AMPS	40 AMPS	
CUTTING	Oxygen	Electrode	220235	120258	120667	120547	120178	-----	
		Electrode SilverPlus	-----	-----	220084	-----	-----	-----	
		Swirl Ring	220236	120833	120833	020613	120179	-----	
		Nozzle	220237	120259	020605	020690	120182	-----	
		Retaining Cap*	220238	020423	020423	020423	120185	-----	
		Shield	220239	120260	020424	020424	120186	-----	
		(Water Muffler**)	Shield	220295	-----	020566	020566	-----	
		Air	Electrode	-----	-----	120667	120547	-----	120667
			Swirl Ring	-----	-----	020679	020607	-----	020613
			Nozzle	-----	-----	020608	020611	-----	020689
	Retaining Cap*		-----	-----	020423	020423	-----	020423	
	Shield		-----	-----	020424	020448	-----	020688	
	(Water Muffler**)	Shield	-----	-----	020566	020618	-----	-----	
	Argon/Hydrogen	Electrode	-----	-----	020415	020415	-----	-----	
		Swirl Ring	-----	-----	020607	020607	-----	-----	
		Nozzle	-----	-----	020608	020611	-----	-----	
		Retaining Cap*	-----	-----	020423	020423	-----	-----	
		Shield	-----	-----	020602	020448	-----	-----	
	Nitrogen	Electrode	-----	-----	020415	-----	-----	-----	
		Swirl Ring	-----	-----	020607	-----	-----	-----	
Nozzle		-----	-----	020608	-----	-----	-----		
Retaining Cap*		-----	-----	020423	-----	-----	-----		
Shield		-----	-----	020424	-----	-----	-----		
(Water Muffler*)	Shield	-----	-----	020566	-----	-----	-----		
Cutting with counterclockwise gas swirl (substitute designated parts)	Oxygen	Swirl Ring	220244	120834	120834	120252	-----	-----	
		Retaining Cap*	220241	020955	020955	020955	-----	-----	
	Air	Swirl Ring	-----	-----	-----	020956	-----	-----	
		Retaining Cap*	-----	-----	-----	020955	-----	-----	
Argon/Hydrogen	Swirl Ring	-----	-----	020956	020956	-----	-----		
	Retaining Cap*	-----	-----	020955	020955	-----	-----		
Nitrogen	Swirl Ring	-----	-----	020956	-----	-----	-----		
	Retaining Cap*	-----	-----	020955	-----	-----	-----		
GOUGING	Air	Electrode	-----	-----	120667	-----	-----	-----	
		Swirl Ring	-----	-----	020607	-----	-----	-----	
		Nozzle	-----	-----	020615	-----	-----	-----	
		Retaining Cap	-----	-----	020423	-----	-----	-----	
		Shield	-----	-----	020485	-----	-----	-----	
	Argon/Hydrogen	Electrode	-----	-----	020415	-----	-----	-----	
		Swirl Ring	-----	-----	020607	-----	-----	-----	
		Nozzle	-----	-----	020615	-----	-----	-----	
		Retaining Cap	-----	-----	020423	-----	-----	-----	
		Shield	-----	-----	020485	-----	-----	-----	

\* If using the Command THC or other ohmic sensing device, use retaining caps with an IHS tab: for standard cutting –120837 clockwise; 120838 counter clockwise for all cutting currents except 50 A; 120185 for 50 A only. For HySpeed use 220242 clockwise; 220243 counter clockwise.

\*\* Water Muffler cannot be used with 2" 120356 Stainless Steel Torch.

## HySpeed HT2000 torch assembly

- 128381 Standard body , 2" sleeve;
- 128367 Stainless steel body, 2" sleeve
- 128141 Standard body, optional 1 3/4" sleeve

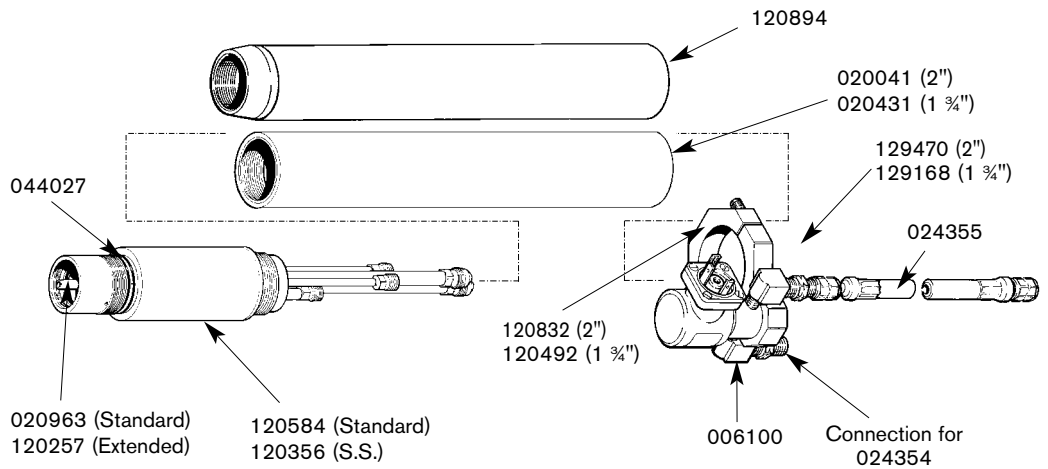

STANDARD BODY PART NO.	DESCRIPTION	STAINLESS STEEL BODY PART NO.
128381	HT2000 Torch Assembly with Valve	128367
120584	MAX200/HT2000 Machine Torch Main Body	120356
020963	Water Tube, Electrode Cooling, Standard	020963
120257	Water Tube, Electrode Cooling, Extended	120257
044027	O-Ring: Buna 70 Duro 1.301 x .070	044027
129470/129168*	HT2000 Off-Valve Assembly	129470
006100	Solenoid Valve, 120# 1/8" FPT	006100
024355	Hose, Off-Valve Assembly to Torch Main Body, 1'	024355
120894/020431	Torch Mounting Sleeve	020041
020407	Adapter: 1 3/4" - 2" Torch Mounting Sleeve	Not Needed
120832/120492**	Valve Mounting Bracket	120832
123185	Torch Off-Valve Cable (not shown)	123185
024354	Hose, Motor-Valve Box to Off-Valve Assembly, 10.25'	024354

\*129168 Off-Valve Assembly is required with the optional 020431 1-3/4" Mounting Sleeve.  
 \*\* 120492 Valve Mounting Bracket is required with the 020431 Mounting Sleeve.

## HySpeed HT2000LHF torch assembly

- 128255 Standard body - 2" sleeve
- 128369 Stainless steel body - 2" sleeve

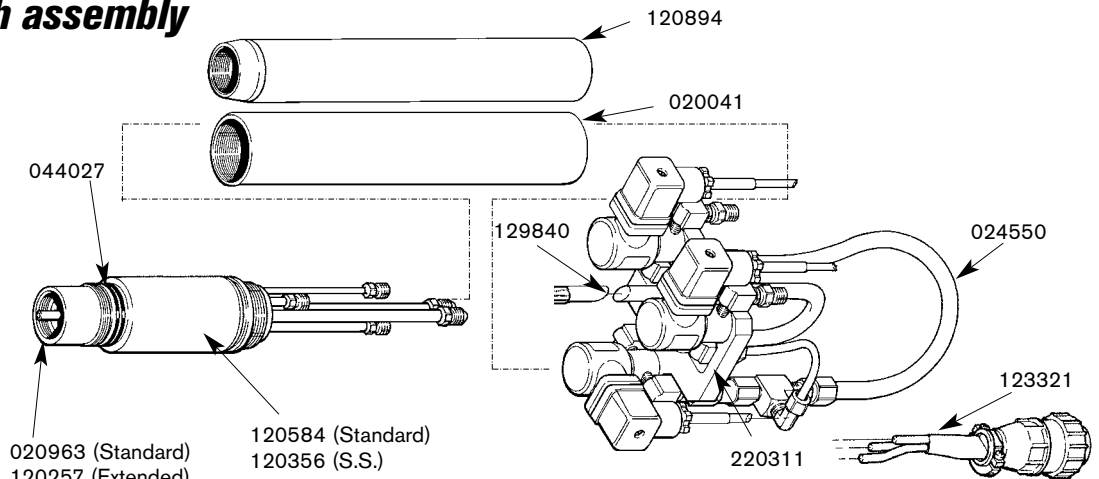

STANDARD BODY PART NO.	DESCRIPTION	STAINLESS STEEL BODY PART NO.
128255	HT2000 Torch Assembly with Valve	128369
120584	MAX200/HT2000 Machine Torch Main Body	120356
120894	Torch Mounting Sleeve: 2"	020041
020963	Water Tube: Electrode Cooling, Standard	020963
120257	Water Tube: Electrode Cooling, Extended	120257
044027	O-Ring: Buna 70 Duro 1.301 x .070	044027
024550	Hose, Off-Valve Assembly to Torch Main Body	024550
123321	Cable: HT2000LHF Torch Off-Valve 24"	123321
129290	Off-Valve Sub Assembly	129840
220311	Bracket: HT2000LHF Off-Valve	220311

**Hypertherm**<sup>®</sup>

The world leader in  
plasma cutting technology™

www.hypertherm.com